

Pillow Talk

ASSEMBLY INSTRUCTIONS

TUPELO COFFEE TABLE

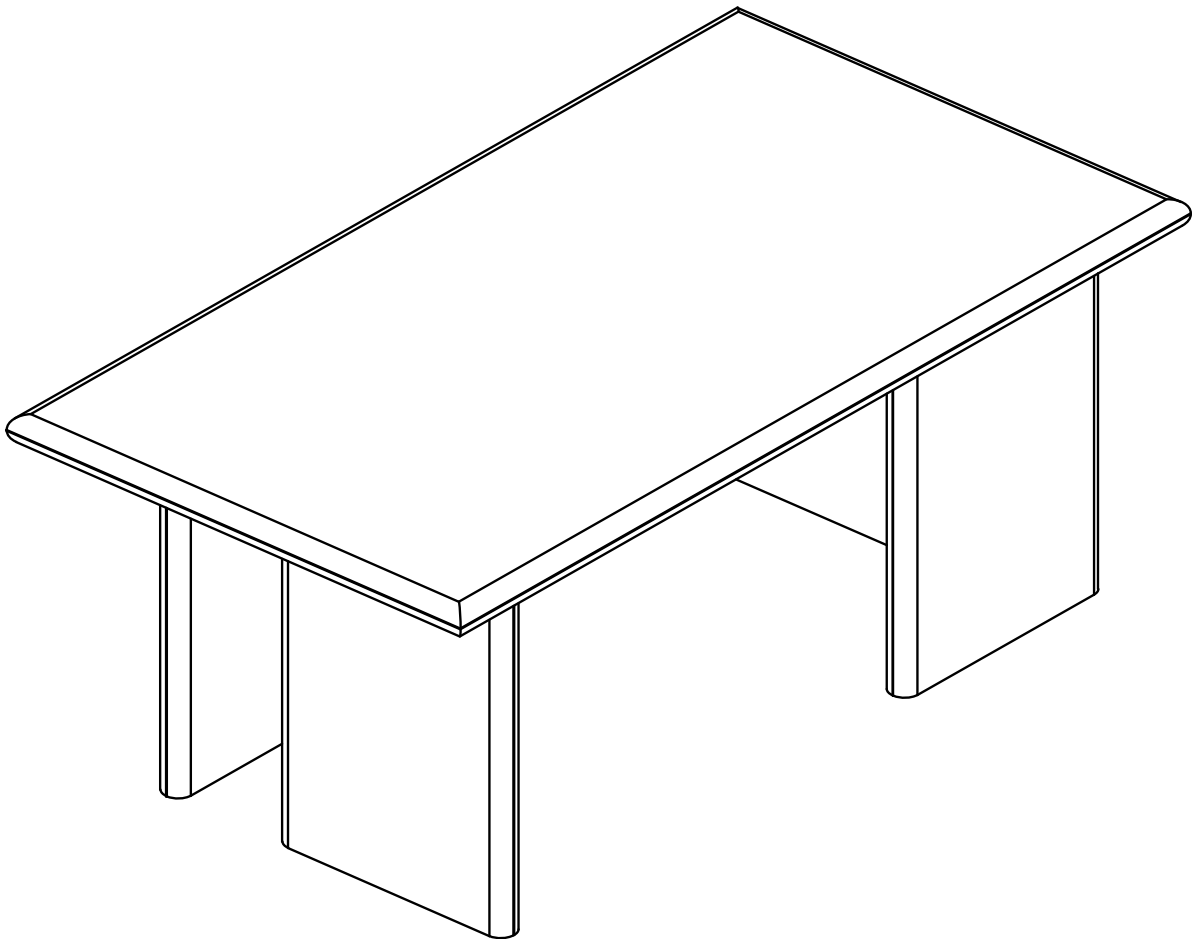

BEFORE ASSEMBLY

Thank you for purchasing this quality product. This product has been designed for easy assembly and constructed for durability. All parts were checked prior to packaging to insure quality. Prior to beginning assembly, however, make sure all parts and hardware are included and free of obvious defect. If a part is missing or defective, please contact the Pillow Talk store where the goods were purchased.

IMPORTANT NOTE:

- Place all parts on a clean and smooth surface such as a rug or carpet to avoid the parts from being scratched.
- Remove all wrapping material, including staples & packing straps before you start to assemble.
- DO NOT tighten all screws and bolts until completely assembled.
- Keep all hardware parts out of reach of children.

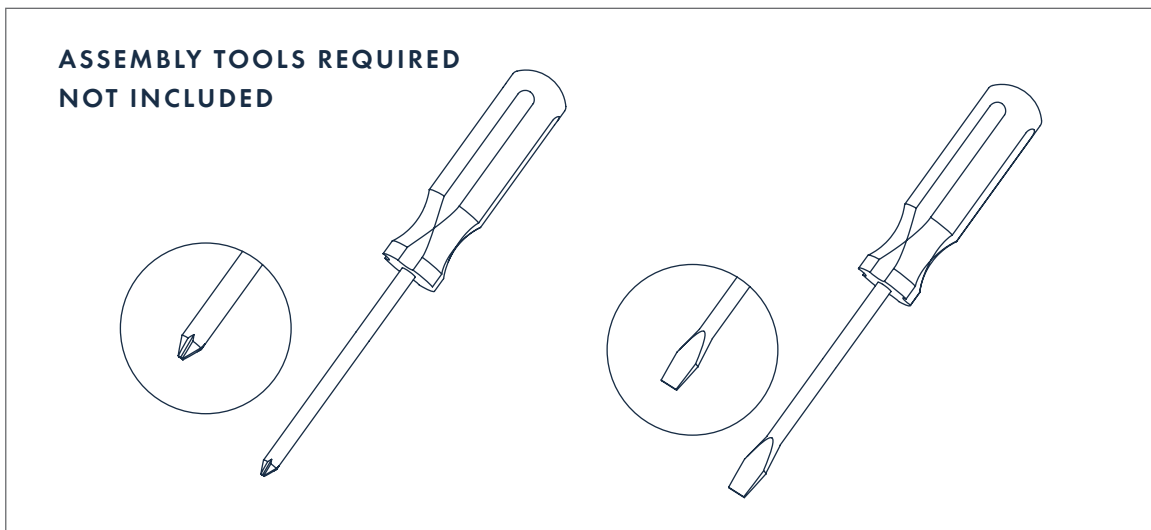

PARTS LIST



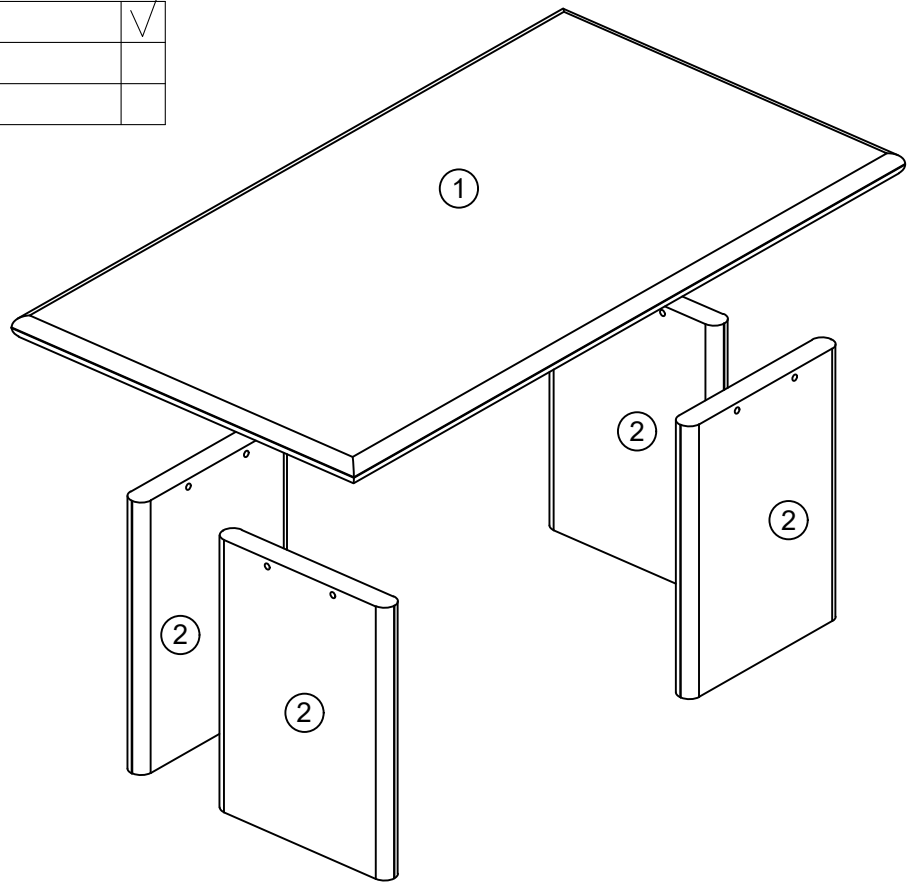

When unpacking, please be careful not to discard any parts with the packaging.
Before continuing, please make sure you have the following parts:

			✓
①	1	1100x600x35	
②	4	436x300x35	



HARDWARE LIST

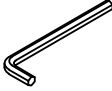

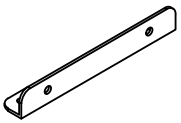
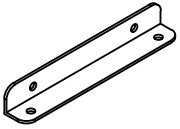
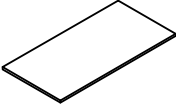

When unpacking, please be careful not to discard any parts with the packaging.
Before continuing, please make sure you have all of the following hardware:

<p>A x 8</p>  <p>M6x35 mm</p>	<p>B x 8</p>  <p>M6x12 mm</p>	<p>C x 1</p>  <p>4 mm</p>	<p>D x 16</p>  <p>M6x15 mm</p>	<p>E x 4</p>  <p>175x25x25 mm</p>
<p>F x 4</p>  <p>175x25x25 mm</p>	<p>G x 8</p>  <p>40x30x3 mm</p>			

(The hardware quantities listed above are required, For proper assembly some extra hardware may have been included.)

ASSEMBLY STEPS

Step 1

A x 8	B x 8	C x 1	E x 4	F x 4
				
M6x35 mm	M6x12 mm	4 mm	175x25x25 mm	175x25x25 mm

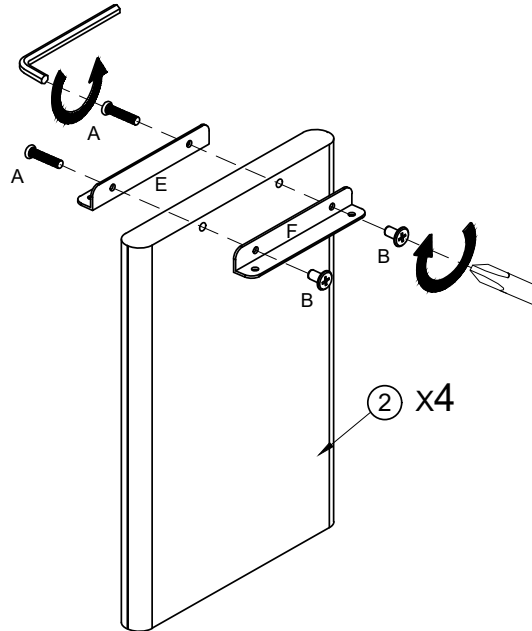
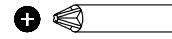

Step 2

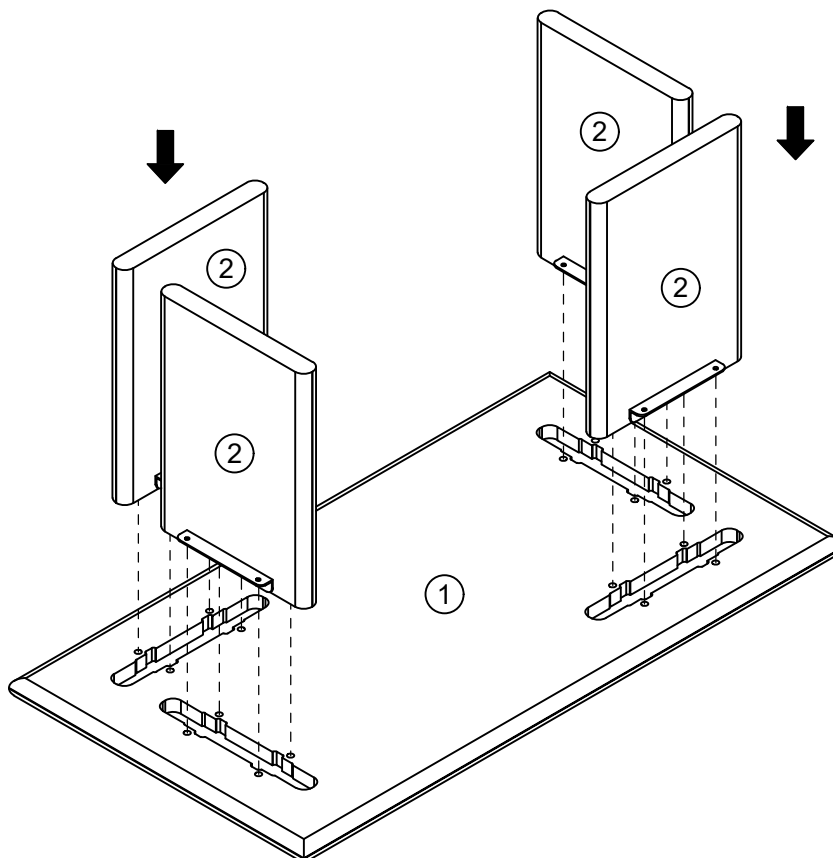

ASSEMBLY STEPS

Step 3

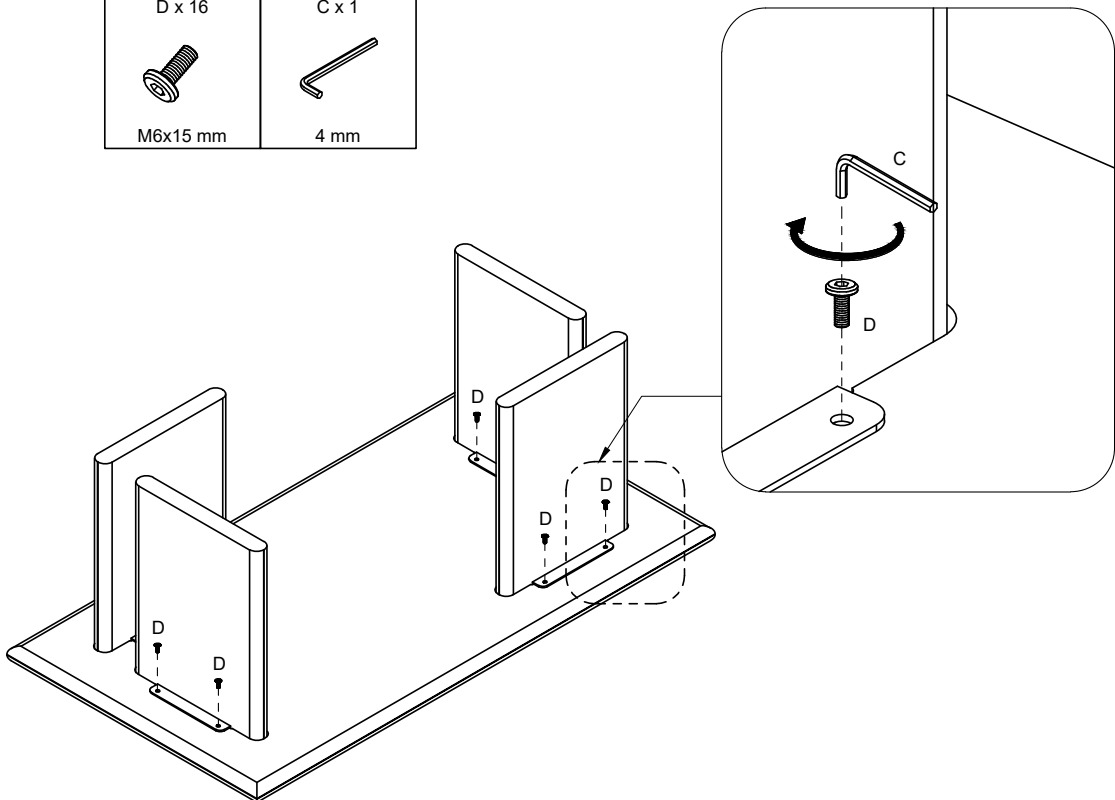
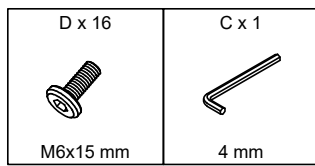

Step 4

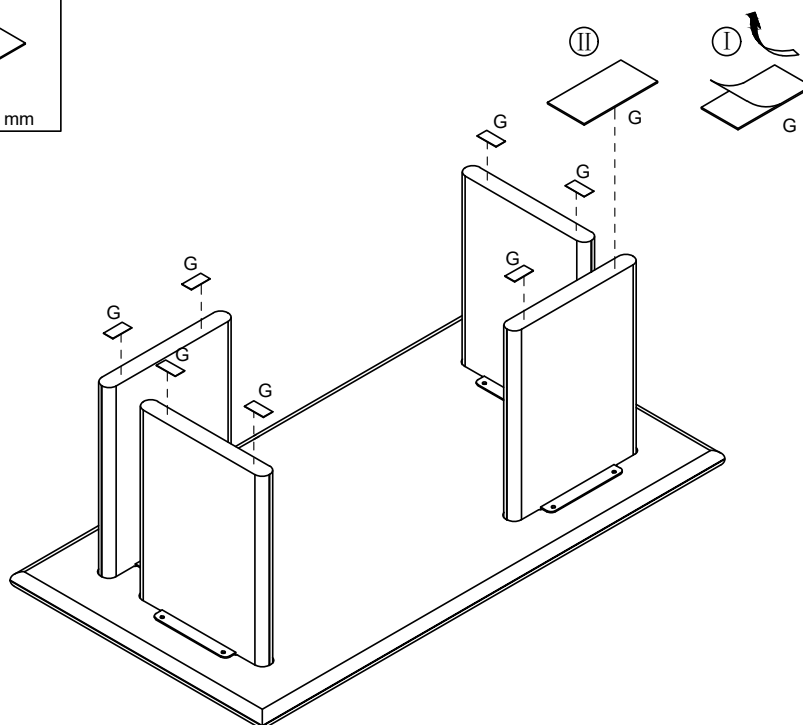
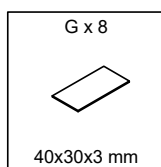

ASSEMBLY STEPS

